

# Reactive power control for smarter (urban) distribution network management with increasing integration of renewable prosumers

Arsalan Zaidi <sup>a\*</sup>, Keith Sunderland<sup>a</sup>, Massimiliano Coppo <sup>b</sup>, Michael Conlon<sup>a</sup>, Roberto Turri<sup>b</sup>

<sup>a</sup>Dublin Institute of Technology (DIT), St Kevin Str., Dublin 8, Ireland  
<sup>b</sup>University of Padova, Padova, Italy

**Abstract:** Smart cities need to deliver reliable electric energy while utilizing every renewable energy source available in a sustainable manner. Increasing renewable electricity capacity, through Distributed Generation (DG) such as small wind and PV generation, causes difficulties for the distribution network operator (DNO) in sustaining adequate and appropriate power quality across the network. The positive impacts provided by such energy sources can be undermined by voltage increases and voltage balance issues. To overcome these problems, urban distribution networks need to transform ideally into smarter energy networks that can deliver renewable electricity locally, predictably and in a controllable and optimized manner. The research presented here is based on electricity network simulation in an urban context. The main focus is the hosting capacity enhancement of distribution networks, while maintaining power quality, which is ultimately a pre-requisite for increasing prosumer engagement. In this regard, a test-bed representation of a 4-wire low-voltage section of distribution network in Dublin, Ireland is developed in DIGSILENT Power Factory. Several scenarios that consider increasing penetration of renewable prosumers in a smart electricity network context are presented. The results show that STATCOM, in the context of increasing DG integration, can provide continuous voltage support, by supplying or absorbing reactive power and thereby facilitating increased renewable DG contributions for a smarter, greener network.

## 1. Introduction:

Over the last decade, cities are becoming engaged in strategic energy developments; availing of indigenous opportunities to contribute towards achieving energy policy goals (Adam, Hoolohan, Gooding, & Knowland, 2015). Cities consume more than 65% of the world's energy requirements and produce more than 60% of the total greenhouse gas emissions, a significant portion of which are derived from fossil fuel based electricity generation. As the global urbanized population is expected to double over the period from 2010 (2.6 billion) to 2050 (5.2 billion), an increase in energy demand is inevitable. Whereas solar PV is increasingly utilised, wind energy within urban environments has yet to be embraced in any meaningful way. Electricity demand is higher in urban centres and wind generation, in conjunction with distributed solar PV generation (DpvG), could supplement centralised generation, which by virtue of fossil fuel reliance, is carbon emission intense (Ayhan & Şafak, 2012).

A major barrier to the effective development of distributed wind generation (DwG) in urban environments, is the complexity of the wind resource. This complexity is further exasperated in cities, where building height heterogeneities promote the propagation of turbulence (Chemisana, 2011). In rural environments on the other hand, the average wind speed is relatively high and the homogeneous landscape promotes laminar air flow and stable (relatively) wind direction. In (Tummala, Velamati, Sinha, Indraja, & Krishna, 2016) and (Bukala, Damaziak, Kroszczyński, Krzeszowieca, & Malachowska, 2015), the authors consider the design and performance of micro DwG (<50kW) in urban environments. That said however, advances in the methods to estimate the wind speed within urban environments, such as that developed by (Millward-Hopkins, Tomlin, Ma, Ingham, & Pourkashanian, 2013) compounded with better understanding of how turbulence impacts on the performance of the

DwG (Emejemara & Tomlin, 2015), (Sunderland, Woolmington, Conlon, & Blackledge, 2013) wind energy could play a bigger role in potential urban wind energy harvesting.

Solar energy is, relatively speaking, more predictable than wind energy harvesting. Building integrated PV (BIPV) is widely recognised as the most cost effective form of PV power generation. It is suitable for urban installations, directly where energy is used and it can share 10-30% of total electricity demand within a city (Sims, 2009). Furthermore, the €/kWp price for solar modules is currently 40% of 2010 values with this trend likely to continue for the foreseeable future (Shah, Mithulananthan, Bansal, & Ramachandaramurthy, 2015).

The work presented here prioritises the technical considerations and effects of DG on low voltage networks. For DNO, maintaining power quality is a big concern in the context of increasing DG connections, where power bi-directionality and increased fault capacities are manifested. Increased DG will also derive voltage increases and the inevitable voltage imbalances can cause damage to electrical equipment (Klonaria, et al., December 2016). This is particularly the case with voltage unbalance caused by increased single-phase connected DG. The voltage unbalance factor (VUF) is defined by the IEEE (Shahnia, Majumder, Ghosh, Ledwich, & Zare, 2011) as,

$$VUF\% = \left| \frac{V_-}{V_+} \right| * 100 \quad \text{Eq. (1)}$$

where,  $V_-$  and  $V_+$  are the negative and positive sequence voltage components respectively. According to the IEEE standard (IEEE, 2009), voltage imbalance must be limited to 2% in low voltage and medium voltage networks for 95% of the time. This issue, in the context of smarter and greener LV networks and increasing DG penetration, requires consideration. Moreover, a means to mitigate voltage implications through some means of dynamic compensation to ensure voltage stability is required.

## 1. STATCOM

A static synchronous compensator (STATCOM) is a regulating device, normally deployed in transmission networks to can act as either a source or sink of network reactive power. In this regard, STATCOM can regulate AC and DC-link voltages in the distribution network. A cascade controller is commonly used to control the voltage source controller (VSC). Two controller loops are employed as shown in Fig. 1. The outer controller consists of two proportional-integral (PI) controllers to eliminate error. Direct-quadrature ( $dq$ ) transformation is employed to transform the three AC quantities into two DC quantities. They generate signals of  $d$  and  $q$  currents for the inner controller, which compares measured and reference voltages at the AC side. The inner controller has two inputs, ( $d$  component and  $q$  component of current). The associated inner-loop regulator subsequently generates active and reactive voltage reference ( $v_d$  and  $v_q$ ) and on that basis the STATCOM absorbs or injects reactive power in the network.

The controller compares the measured and reference DC-link voltages ( $V_{dc\_ref}$ ) (DC-link across capacitor) and sends an error signal to the PI controller which generates a direct-axis current reference 'id'.

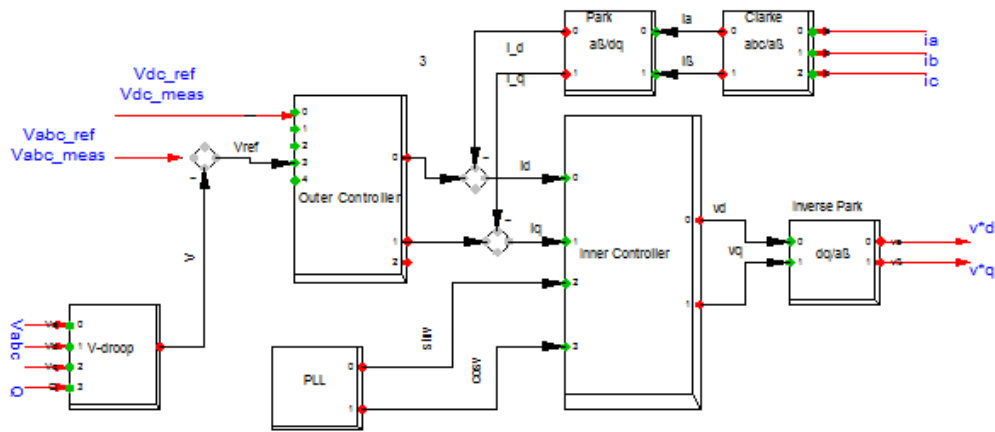

Fig. 1: Basic controller of STATCOM

The Clarke transformation is used to transform time domain signals (voltage, current) from three-phase coordinates into a stationary two-phase reference frame ( $\alpha\beta$  frame) (Bhutto, Bak-Jensen, & Mahat, 2012). The Park transformation converts the stationary  $\alpha\beta$  frame into a rotating a dq frame. A Phase Locked Loop (PLL) is used to compare the actual voltage with the reference voltage, for synchronizing purposes.

The inner loop contains current controllers. One controller is for  $i_d$ , the other one for  $i_q$ . The three phase voltages are measured from the reference terminal in the network and are transformed to  $\alpha\beta$  and then from  $\alpha\beta$  to  $dq$  coordinates by using PLL transformation angle (Bhutto, Bak-Jensen, & Mahat, 2012). Using PLL, the  $d$ -component of current becomes an active current component ( $d$ -current) and the  $q$ -component becomes reactive current component ( $q$ -current) (Xiao-Qiang, Wu, & Gu, 2011). The actual current  $i^?d$  is compared and a difference signal is sent from the PI controller to the built-in current controllers. The output of the PI controller is the reference voltage signal ( $Vq$ ).

### 1.1 Control Technique

The control scheme utilised should be able to maintain constant voltage magnitude when dynamic load and generation are connected to the network; particularly in the context of abrupt system disturbances (single or three phase). Fig. 2 illustrates the block diagram of the control system design implemented for controlling power flow employing PI controllers, V-Q curve input and a PLL

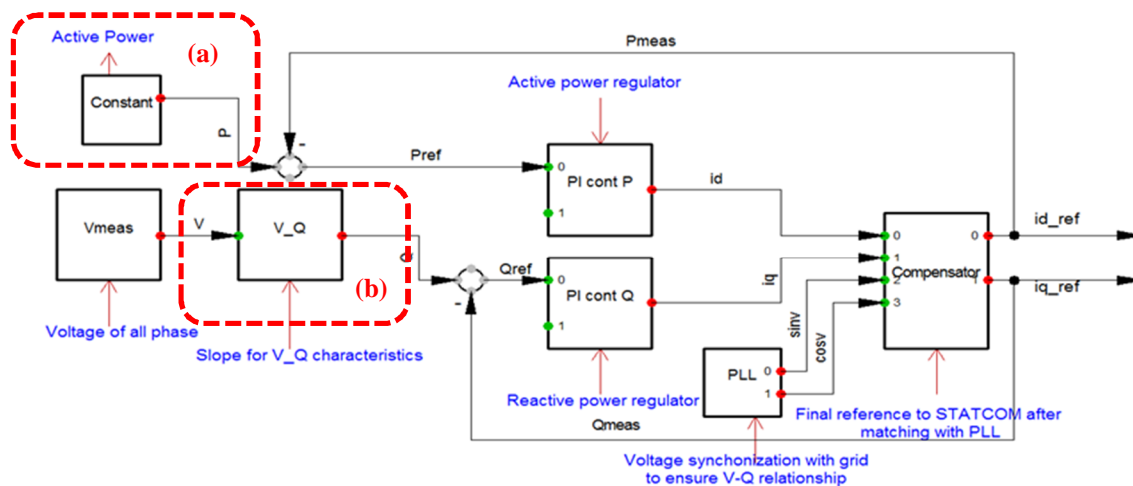

Fig. 2: Proposed STATCOM Control Scheme Block Diagram

The purpose of this control is to provide reactive power support in distribution networks in order to maintain power flow. The proposed controlling scheme does not have a DC link voltage  $V_{dc\_ref}$  as shown in Fig. 1. Instead, the active current component (d-current)  $id$  as shown in Fig. 1 is controlled with constant active power, as highlighted [(a)] in Fig. 2. Clarke and Park transformation are employed to get reference signals for the controller  $id$  and  $iq$  respectively. The Droop controller is replaced by a  $V\_Q$  curve as highlighted [(b)] in Fig. 2.

As previously described, the PI controller is used to control active and reactive power magnitudes. In the frequency domain, this is stated as,

$$G_{PI}(s) = K_p \left( 1 + \frac{1}{T_i s} \right) \quad \text{Eq. (2)}$$

where,  $K_p$  (Proportional gain) and  $T_i$  (integral time constant) are proportional-integral (PI) controller parameters. The STATCOM performance depends on proper tuning of these parameters. Ziegler-Nichols method is widely used to achieve such tuning. The main factor, causing voltage instability, is the network inability to meet reactive power demand and this becomes increasingly prevalent with increased contributions from DG. In power systems,  $P\_V$  (MW) and  $Q\_V$  (MVar) curves are employed as references to maintain voltage levels in networks within acceptable tolerances. The  $Q\_V$  curve represents reactive power demanded at the specific terminal as voltage level changes. This reference current signal  $Q_{ref}$  controls the compensator. Feedback to the compensator is facilitated through  $P_{meas}$  once it is 'matched' to the  $P$  signal. If the value of  $P_{ref}$  is not zero then the PI controller rectifies it and sends an  $id$  signal to compensator until  $P_{meas}$  and  $P$  values derive a  $P_{ref}$  value that is zero. In the reactive power controller,  $V_{meas}$  facilitates measurement of the three phase voltage as dynamic voltage reference at the desired location. The  $Q\_V$  block takes the reference voltage,  $V_{meas}$ , input and matches it with  $Q\_V$  curve. If  $V_{meas}$  is less than reference voltage stipulated by the  $Q\_V$  curve then  $Q_{meas}$  signal is higher than  $Q$  signal. The control  $Q_{ref}$  signal is negative, which means positive  $Iq$  signal to compensator. The Phase-Locked-Loop (PLL block), it is used to generate an output signal that relates the phase of the control variable in respect to the input reference signal. The PLL utilises a controlled oscillator that synchronizes the control variable to the reference network signal. Essentially, the PLL provides a reference for the voltage angle that the STATCOM employs to relate voltage and current while calculating reactive power.

## 2. Network Modelling

The network model is implemented on the DIgSILENT power factory platform. There are 74 customers, connected from a 10/0.4 kV transformer in a radial network topology. In this regard the LV distribution network considered in (Sunderland K. , Coppo, Conlon, & Turri, 2016) illustrated in Fig. 3 below is employed. Hourly DwG, DpvG generator outputs and load demand, based on (Sunderland K. , Coppo, M. , Conlon, & Turri, 2013), are utilised. The STATCOM capacity employed in the analysis considered is 10 kVAr.

As defined in the EN50160 standard (Markiewicz & Klajn, 2004), the voltage at every bus of the medium and low voltage network should be within  $\pm 10\%$  of its nominal value, with  $\pm 6\%$  being employed by the network designers. In terms of loading, the maximum limit is 80% both for transformer and cables. Overloading can increase losses in a network. In Ireland, consistent with EN50438, microgeneration (DwG / DpvG) is defined as generation units that can produce 25A at 230 V or 16A at 400 V, as for the guidelines published by ESB Networks (Irish DNO) (Sunderland K. , Coppo, Conlon, & Turri, 2016). 01/04/2012 is selected randomly for extraction of 24-hours generation and load profiles. The network generation connection strategy illustrated in (Sunderland K. , Coppo, Conlon, & Turri, 2016) is used. In this regard therefore, the load/generation pertaining to the day being considered is employed with the generator profiles. Therefore, for the DwG – the methodology presented in (Sunderland K. ,

Coppo, M. , Conlon, & Turri, 2013) was used; for the DpvG, the Skoplaki methodology (Skoplaki, Boudouvis, & Palyvos, 2008) was employed and for load profiles, the Commission for Energy Regulation (CER, 2017) load data sets were applied. In terms of the generation, local meteorology measurements from an urban site in Dublin, Ireland were employed.

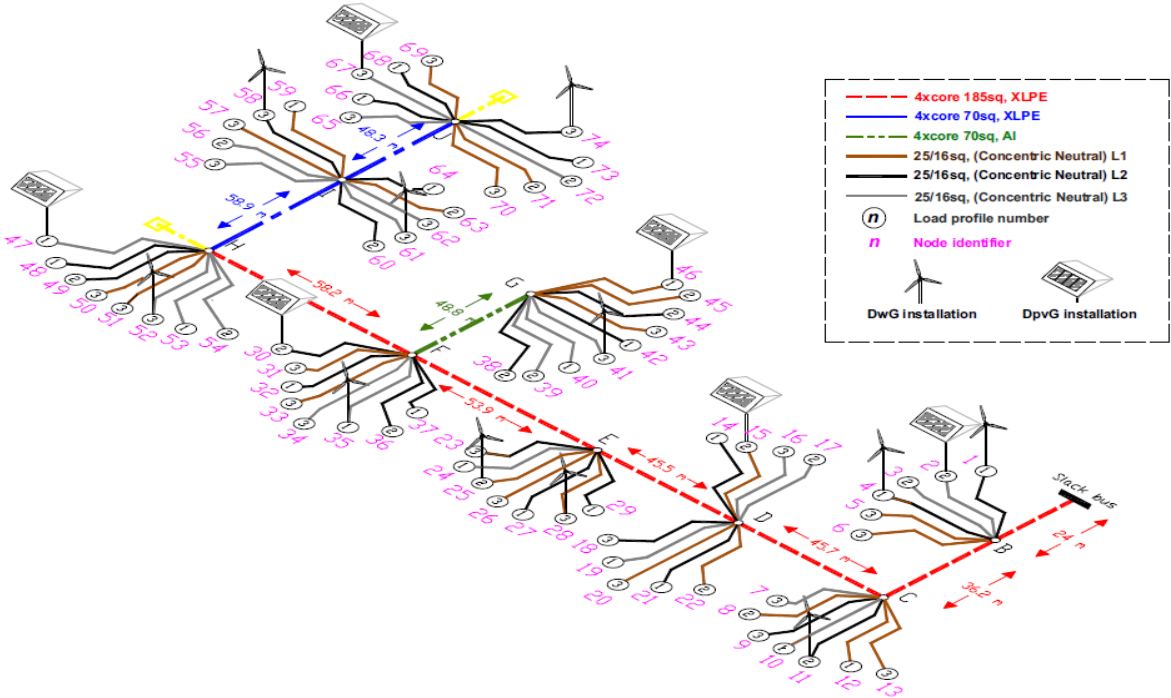

Fig. 3: Section of Irish distribution network containing DG (DwG and DpvG) (Sunderland K. , Coppo, Conlon, & Turri, 2016)

**3. Analysis**

The context for analysis is consistent with (Sunderland K. , Coppo, Conlon, & Turri, 2016) with an hourly profile representing both load/generation demands and associated wind and solar resources over the same period (April 2012). The specific scenario considered in this research is in respect to generation being increased to 300% nominal.

Fig. 4(a) and (b) illustrate the voltage profile at pillars E and J respectively in term of 300% generation. Phase A is essentially maintained at 1 pu irrespective of where the STATCOM is connected while the voltages observed for phases B and C will vary depending on positioning of the STATCOM. If, however, the STATCOM is connected to pillar J, at the far-end of the radial network, the phase voltages (A, B and C) increase from a 0.99-1.02 pu range to 1.05-1.11 pu. STATCOM is not able to maintain the voltage at 1 pu throughout 24 hours. In fact it has the effect of increasing the voltage. This voltage rise is attributable to a lower wind resource being observed between hours of 08:00 – 24:00 and minimal DwG contribution. The STATCOM essentially over compensates in this time period resulting in voltage tolerance breaches. In other words, the network has sufficient access to reactive power without the STATCOM to maintain voltage level.

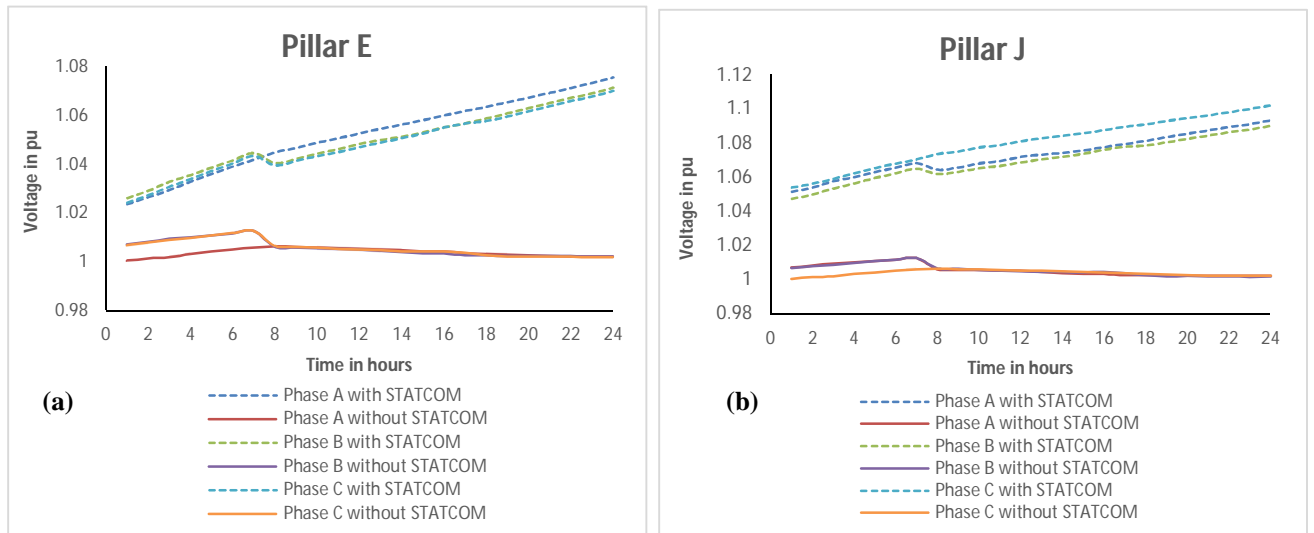

Fig. 4: Network Voltage with and without STATCOM at different pillars

The STATCOM, over this time period, is essentially absorbing the reactive power as shown in Fig. 5. STATCOM can either inject or absorb reactive power in respect to all phases simultaneously. However, it is not possible to control all three phases with one STATCOM for unbalanced load conditions. Individual ‘per-phase’ STATCOMs would be required if over/under-voltage problems were to occur simultaneously. At pillars E and J, the voltage level compensated through STATCOM are 0.02 pu and 0.04 pu respectively. It is evident therefore that a connection at pillar J will compensate 3.5-4.0% of voltage level in pu, while reactive power is being absorbed by the STATCOM.

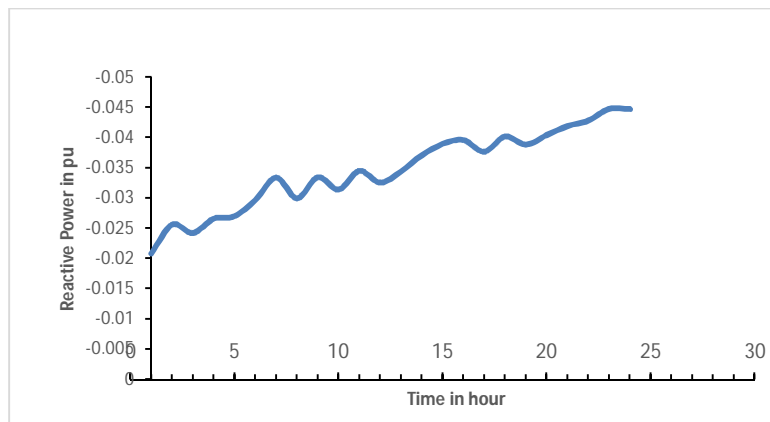

Fig. 5: Reactive power compensated by STATCOM at pillar J

The voltage unbalance factor is calculated on pillar B, E and J, again with 300% increase in generation. The VUF is observed to decrease on each of the pillars considered (B, E and J), with the exception of pillar J as shown in Fig. 6. It is also evident that with simultaneous voltage variations, the STATCOM is able to decrease (control) the VUF across the network. That said, if the STATCOM is connected to Pillar J, as all the reactive power absorbed from the network over the period in question passes through Pillar J, the STATCOM is less capable of VUF control at this pillar.

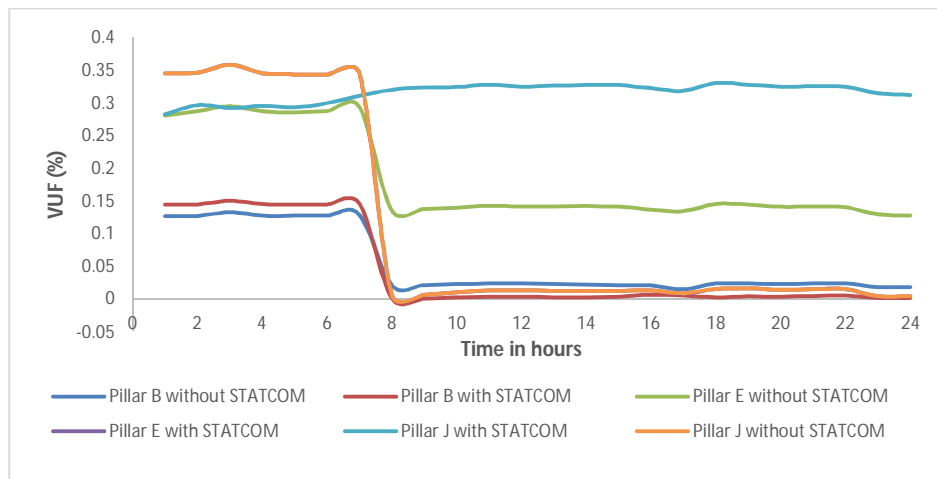

Fig. 6: Voltage Unbalance Factor (VUF) with and without STATCOM at different Pillars

#### 4. Conclusion

This paper considers the implication for distribution networks in the context of increased building integrated and/or urban deployed DG. In the context of the built environment, urbanisation presents a significant challenge where cities are increasingly becoming energy sinks. However, renewable energy opportunities may also offer sources for energy if network integrity can be assured. In this regard, the analysis presented here considers a novel approach to voltage control, as primary consequence of increased network connected DG, using a technology (STATCOM) usually found in transmission networks. Such technology assists in facilitating an increased level of built environment engagement in the context of smarter and greener cities.

The results suggest that DG penetration closest to the upstream MV grid, in the context of an exemplar urban distribution network, will have less impact on voltage profile than DGs connected to the far end of the radial network. The voltage profile across the network will vary according to location and rating of DGs. DGs are connected to the network as single phase sources, but as such, they can impact voltage level on all (three) phases with the voltage unbalance factor also being affected. Under the conditions considered (April, 2012) in terms of the consumer demand and DG (DwG and DpvG), voltage breaches were not observed until the DG output was increased to 300% in the network (Fig 3, (Sunderland K. , Coppo, Conlon, & Turri, 2016)). STATCOM is able to maintain voltage levels within limits during the time period 00:00-08:00 on this date. However, the voltage profile in the subsequent period is greatly affected by both the lack of generation capacity (due to a diminished wind resource) and also the power rating of STATCOM. The latter, in the context of a high capacity STATCOM will result in an over-compensated voltage profile Fig. 4. In this regard therefore, the rating of the STATCOM is an essential consideration. STATCOM however, is able to reduce VUF quick effectively and as such also serves to reduce voltage fluctuations in the network. STATCOM is not at present a cost-optimal method for distribution network voltage support and further work in the context of opportunity cost associated with such innovation is required. That said, STATCOM is very diversifiable and can readily accommodate other forms of renewable energy sources and electric vehicle penetration.

#### 5. References

Adam, K., Hoolohan, V., Gooding, J., & Knowland, T. (2015). Methodologies for city-scale assessment of renewable energy generation potential to inform strategic energy infrastructure investment. *CITIES*, 12. doi:10.1016/j.cities.2015.10.015



